

# TRUCK CRANE

## TL-250M

*JAPANESE SPECIFICATIONS*

**TL**

CARRIER MODEL	OUTLINE	SPEC. NO.
NISSAN DIESEL P-KG45S	4-section Boom, 2-stage Jib	TL-250M-3-10101
MITSUBISHI P-K303		TL-250M-3-20101

**Control No. JA-02**

# TL-250M

## CRANE SPECIFICATIONS

### CRANE CAPACITY

10.5m Boom	25,000kg	at 3.5m	( 8 part-line)
14.2m Boom	20,000kg	at 4.5m	( 7 part-line)
18.0m Boom	16,000kg	at 5.0m	( 7 part-line)
21.7m Boom	12,000kg	at 6.0m	( 4 part-line)
25.5m Boom	11,500kg	at 6.0m	( 4 part-line)
29.2m Boom	9,000kg	at 7.0m	( 4 part-line)
33.0m Boom	7,000kg	at 8.0m	( 4 part-line)
8.5m Jib	3,000kg	at 75°	( 1 part-line)
14.5m Jib	2,000kg	at 77°	( 1 part-line)
Single top	3,400kg		( 1 part-line)

### MAX. LIFTING HEIGHT

Boom	32.9m
Jib	47.0m

### MAX. WORKING RADIUS

Boom	30.0m
Jib	36.9m

### BOOM LENGTH

10.5m – 33.0m

### BOOM EXTENSION

22.5m

### BOOM EXTENSION SPEED

22.5m / 125s

### JIB LENGTH

8.5m, 14.5m

### MAIN WINCH SINGLE LINE SPEED

High range:	122m/min	(4th layer)
Low range:	61m/min	(4th layer)

### MAIN WINCH HOOK SPEED

High range:	15.2m/min	(8 part-line)
Low range:	7.6m/min	(8 part-line)

### AUXILIARY WINCH SINGLE LINE SPEED

High range:	104m/min	(2nd layer)
Low range:	52m/min	(2nd layer)

### AUXILIARY WINCH HOOK SPEED

High range:	104m/min	(1 part-line)
Low range:	52m/min	(1 part-line)

### BOOM ELEVATION ANGLE

-3° – 80°

### BOOM ELEVATION SPEED

-3° – 80° / 70s

### SWING ANGLE

360° continue

### SWING SPEED

2.5rpm

### WIRE ROPE

#### Main Winch

16mm × 180m (Diameter×Length)  
7×7+6×Fi(29) Class B ordinary · Z twist  
Spin-resistant wire rope  
Breaking strength 17.6t

#### Auxiliary Winch

16mm × 105m (Diameter×Length)  
7×7+6×Fi(29) Class B ordinary · Z twist  
Spin-resistant wire rope  
Breaking strength 17.6t

### BOOM

4-section hydraulically telescoping boom of box construction.  
(stage 2: sequential; stages 3,4: synchronized)

### BOOM EXTENSION

2 double-acting hydraulic cylinder  
1 wire rope type telescoping device

### JIB

2-staged swingaround boom extension which stores alongside boom base section.  
Triple offset (5°, 25°, 45°) type

### SINGLE TOP

Single sheave. Mounted to main boom head for single line work.

### HOIST

Hydraulic motor driven planetary gear reducer  
With free-fall device.  
Automatic brake (with foot brake for free-fall device)  
2 single winches

### BOOM ELEVATION

1 double-acting hydraulic cylinders

### SWING

Hydraulic motor driven planetary gear reducer  
Swing bearing  
Swing free/lock changeover type  
Hand brake

### OUTRIGGERS

Fully hydraulic H-type (floats mounted integrally)  
Slides and jacks each provided with independent operation device.

Full extended width	6.1m
Middle extended width	4.0m

### FRONT JACK

Hydraulic operated type

### MAX. OUTRIGGER LOAD

30.0t

Transmission P.T.O.

### HYDRAULIC PUMPS

3 gear pumps

### HYDRAULIC OIL TANK CAPACITY

432 liters

### SAFETY DEVICES

Automatic moment limiter (AML)  
Working area control device  
Over-winding cutout  
Level gauge  
Hook safety latch  
Winch drum lock  
Hydraulic safety valve  
Telescopic counterbalance valve  
Elevation counterbalance valve  
Jack pilot check valve  
Front jack over load alarm

### EQUIPMENTS

Boom angle indicator  
Oil cooler  
Crane cab heater  
Radio  
Fan  
Block

## CARRIER SPECIFICATIONS

### MANUFACTURER

NISSAN DIESEL MOTOR CO., LTD

### CARRIER MODEL

P-KG45S

### ENGINE

Model PE6 (with turbo)

Type 4-cycle, in-line 6-cylinder, direct-injection water-cooled diesel engine

Piston displacement 11,670cc

Max. output 280PS at 2,200rpm

Max. torque 110kg·m at 1,200rpm

### CLUTCH

Dry single-plate coil spring type

### TRANSMISSION

6-forward and 1-reverse speeds

Constant-mesh gear (1st speed, reverse)

Synchronized-mesh gear (2nd – 6th speeds)

### REDUCER

Hypoid gear type

### FRONT AXLE

Reverse Elliot-type steel pipe cross section

### REAR AXLE

Full floating, cast torque rods

### SUSPENSION

Front Laminated leaf spring type

Rear Equalizer and torque rods

### STEERING

Recirculating ball screw type with linkage power assistance

### BRAKE SYSTEM

Service Brake

2-circuit hydro-pneumatic type, 8-wheels internal expanding brake

Parking Brake

Mechanically operated, duo-servo shoe type acting on drum at transmission case rear.

Auxiliary Brake

Electro-pneumatic operated exhaust brake

### ELECTRIC SYSTEM

24 V DC. 2 batteries of 12V (120Ah)

### FUEL TANK CAPACITY

200 liters

### CAB

Two-man type

### TIRES

Front 10.00-20-14PR

Rear 10.00-20-14PR

### STANDARD EQUIPMENTS

Car heater

Car radio

## GENERAL DATA

### DIMENSIONS

Overall length 12,540mm

Overall width 2,490mm

Overall height 3,400mm

Wheel base 1,520mm + 3,530mm + 1,300mm = 6,350mm

Tread Front 2,025mm

Rear 1,860mm

### WEIGHTS

Gross vehicle weight

Total 28,100kg

Front 9,760kg

Rear 18,340kg

### PERFORMANCE

Max. traveling speed 60km/h

Gradeability (tan  $\theta$ ) 0.42

Min. turning radius 10.5m

## CARRIER SPECIFICATIONS

### MANUFACTURER

MITSUBISHI MOTOR CORPORATION

### CARRIER MODEL

P-K303

### ENGINE

Model 8DC8

Type 4-cycle V8-cylinder, direct-injection, water-cooled diesel engine

Piston displacement 14,886cc

Max. output 290PS at 2,200rpm

Max. torque 100kg·m at 1,400rpm

### CLUTCH

Dry single-plate type, hydraulic control with clutch booster

### TRANSMISSION

5-forward and 1-reverse speeds

Constant-mesh gear (1st speed, reverse)

Synchronized-mesh gear (2nd - 5th speeds)

### REDUCER

1-stage speed reduction type

Hypoid gear type

### FRONT AXLE

Reverse-elliot type steering knuckles

### REAR AXLE

Full-floating type, cast-steel housing

### SUSPENSION

Front Laminated semi-elliptical leaf spring type

Rear Equalizer beam and torque rod type

### STEERING

Recirculating ball screw type

Integral power steering

### BRAKE SYSTEM

Service Brake

Foot operated full air brake on all wheels, air over hydraulic type, internal expanding leading and trailing shoe type.

Parking Brake

Mechanically operated, internal expanding duo-servo shoe type acting on drum at transmission case rear.

Auxiliary Brake

Exhaust brake

### ELECTRIC SYSTEM

24 V DC. 2 batteries of 12V (140Ah)

### FUEL TANK CAPACITY

200 liters

### CAB

Two-man type

### TIRES

Front 10.00-20-14PR

Rear 10.00-20-14PR

### STANDARD EQUIPMENTS

Car heater

Car radio

## GENERAL DATA

### DIMENSIONS

Overall length 12,540mm

Overall width 2,490mm

Overall height 3,400mm

Wheel base 1,450mm + 3,600mm + 1,350mm = 6,400mm

Tread Front 2,050mm

Rear 1,845mm

### WEIGHTS

Gross vehicle weight

Total 28,100kg

Front 9,900kg

Rear 18,200kg

### PERFORMANCE

Max. traveling speed 65km/h

Gradeability (tan θ) 0.33

Min. turning radius 11.0m

**TOTAL RATED LOADS**

(1)

Unit : ton

· Outriggers fully extended + Front jack (360°) · Outriggers fully extended (Over rear · Over sides)							
A \ B (m)	10.5m	14.2m	18.0m	21.7m	25.5m	29.2m	33.0m
3.0	25.00	20.00	16.00				
3.5	25.00	20.00	16.00	12.00			
4.0	22.90	20.00	16.00	12.00	11.50		
4.5	21.00	20.00	16.00	12.00	11.50		
5.0	19.40	18.40	16.00	12.00	11.50	9.00	
5.5	17.70	16.80	14.75	12.00	11.50	9.00	7.00
6.0	16.20	15.30	13.70	12.00	11.50	9.00	7.00
7.0	13.70	12.65	11.95	11.00	10.00	9.00	7.00
8.0	11.40	10.65	10.55	10.20	8.90	8.20	7.00
9.0		8.85	8.75	9.20	8.05	7.45	6.25
10.0		7.20	7.10	7.50	7.30	6.75	5.70
12.0		5.00	4.90	5.25	5.60	5.65	4.80
14.0			3.50	3.85	4.15	4.30	4.10
16.0			2.50	2.85	3.15	3.30	3.40
18.0				2.15	2.40	2.55	2.65
20.0				1.60	1.85	2.00	2.10
22.0					1.40	1.55	1.65
24.0						1.20	1.30
26.0						0.90	1.00
28.0							0.75
30.0							0.50

A = Boom length B = Working radius

Unit : ton

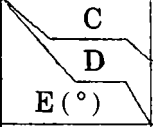
· Outriggers fully extended + Front jack (360°) · Outriggers fully extended (Over rear · Over sides)						
 E (°)	8.5 m			14.5 m		
	5°	25°	45°	5°	25°	45°
80	3.00	1.70	1.00	2.00	0.90	0.60
77	3.00	1.70	1.00	2.00	0.90	0.60
76	3.00	1.70	1.00	1.92	0.90	0.60
75	3.00	1.67	0.96	1.81	0.87	0.59
70	2.28	1.47	0.87	1.40	0.80	0.55
65	1.85	1.29	0.81	1.12	0.74	0.51
60	1.57	1.16	0.76	0.92	0.66	0.48
55	1.15	1.04	0.70	0.75	0.58	0.45
50	0.75	0.70	0.65	0.55	0.50	0.42
45	0.45	0.45	0.40	0.35	0.30	0.25
43	0.35	0.35		0.25		
41	0.25	0.25				

C = Jib length D = Jib offset E = Boom angle

**NOTES:**

1. The total rated loads shown are for the case when the outriggers are set horizontally on firm ground. The values are based on the crane strength.
2. The weights of the slings and hooks (main winch hook: 280kg, auxiliary winch hook: 60kg) are included in the total rated loads shown.
3. The total rated load is based on the actual working radius including the deflection of the boom.
4. The chart below shows the standard number of part lines for each boom length. The load per line should not exceed 3.2t for the main winch and 3.4t for the auxiliary winch.

A	10.5m	14.2m	18.0m	21.7m	25.5m	29.2m	33.0m	J
H	8	7	7	4	4	4	4	1

A = Boom length H = No. of part-line J = Jib / Single top

5. As a rule, free-fall operations should be performed only when lowering the hook alone. If a hoisted load must be lowered by free-fall operation, the load must be kept below 1/5th of the total rated load (the load per line must be 0.7t or less) and sudden braking operations must be avoided.
6. The total rated loads for the single top are obtained by subtracting the corresponding values below from the total rated load of the boom and must not exceed 3.4t.

A	10.5m	14.2m	18.0m	21.7m	25.5m	29.2m	33.0m
Q	0kg	100kg	100kg	200kg	200kg	250kg	250kg

A = Boom length Q = Subtracted load

(2)

Unit : ton

· Outriggers middle extended (360°) · Outriggers fully extended (Over front)							
A \ B (m)	10.5m	14.2m	18.0m	21.7m	25.5m	29.2m	33.0m
3.0	25.00	20.00	16.00				
3.5	23.00	20.00	16.00	12.00			
4.0	20.00	20.00	16.00	12.00	11.50		
4.5	17.40	17.20	16.00	12.00	11.50		
5.0	14.00	13.80	13.60	12.00	11.50	9.00	
5.5	11.65	11.45	11.30	11.70	11.50	9.00	7.00
6.0	9.85	9.70	9.60	10.00	10.40	9.00	7.00
6.5	8.45	8.30	8.20	8.60	9.00	9.00	7.00
7.0	7.35	7.20	7.10	7.50	7.85	8.05	7.00
7.5	6.40	6.30	6.20	6.60	6.95	7.15	7.00
8.0	5.65	5.55	5.45	5.85	6.15	6.35	6.50
9.0		4.35	4.25	4.65	4.95	5.10	5.25
10.0		3.45	3.40	3.75	4.05	4.20	4.35
12.0		2.10	2.05	2.40	2.70	2.90	3.05
14.0			1.15	1.50	1.80	1.95	2.10
16.0			0.45	0.90	1.15	1.30	1.45
18.0					0.70	0.85	1.00

Unit : ton

· Outriggers middle extended (360°) · Outriggers fully extended (Over front)						
E (°)	8.5 m			14.5 m		
	5°	25°	45°	5°	25°	45°
80	3.00	1.70	1.00	2.00	0.90	0.60
77	3.00	1.70	1.00	2.00	0.90	0.60
76	3.00	1.70	1.00	1.92	0.90	0.60
75	2.90	1.67	0.96	1.81	0.87	0.59
70	1.65	1.35	0.87	1.25	0.80	0.55
65	0.80	0.70	0.65	0.60	0.50	0.40
63	0.55	0.50	0.45			

A = Boom length B = Working radius C = Jib length D = Jib offset E = Boom angle

**NOTES:**

1. The total rated loads shown are for the case when the outriggers are set horizontally on firm ground. The values are based on the crane strength.
2. The weights of the slings and hooks (main winch hook: 280kg, auxiliary winch hook: 60kg) are included in the total rated loads shown.
3. The total rated load is based on the actual working radius including the deflection of the boom.
4. The chart below shows the standard number of part lines for each boom length. The load per line should not exceed 3.2t for the main winch and 3.4t for the auxiliary winch.

A	10.5m	14.2m	18.0m	21.7m	25.5m	29.2m	33.0m	J
H	8	7	7	4	4	4	4	1

A = Boom length H = No. of part-line J = Jib / Single top

5. As a rule, free-fall operations should be performed only when lowering the hook alone. If a hoisted load must be lowered by free-fall operation, the load must be kept below 1/5th of the total rated load (the load per line must be 0.7t) and sudden braking operations must be avoided.
6. The total rated loads for the single top are obtained by subtracting the corresponding values below from the total rated load of the boom and must not exceed 3.4t.

A	10.5m	14.2m	18.0m	21.7m	25.5m	29.2m	33.0m
Q	0kg	100kg	100kg	200kg	200kg	250kg	250kg

A = Boom length Q = Subtracted load

### WORKING RADIUS - LIFTING HEIGHT

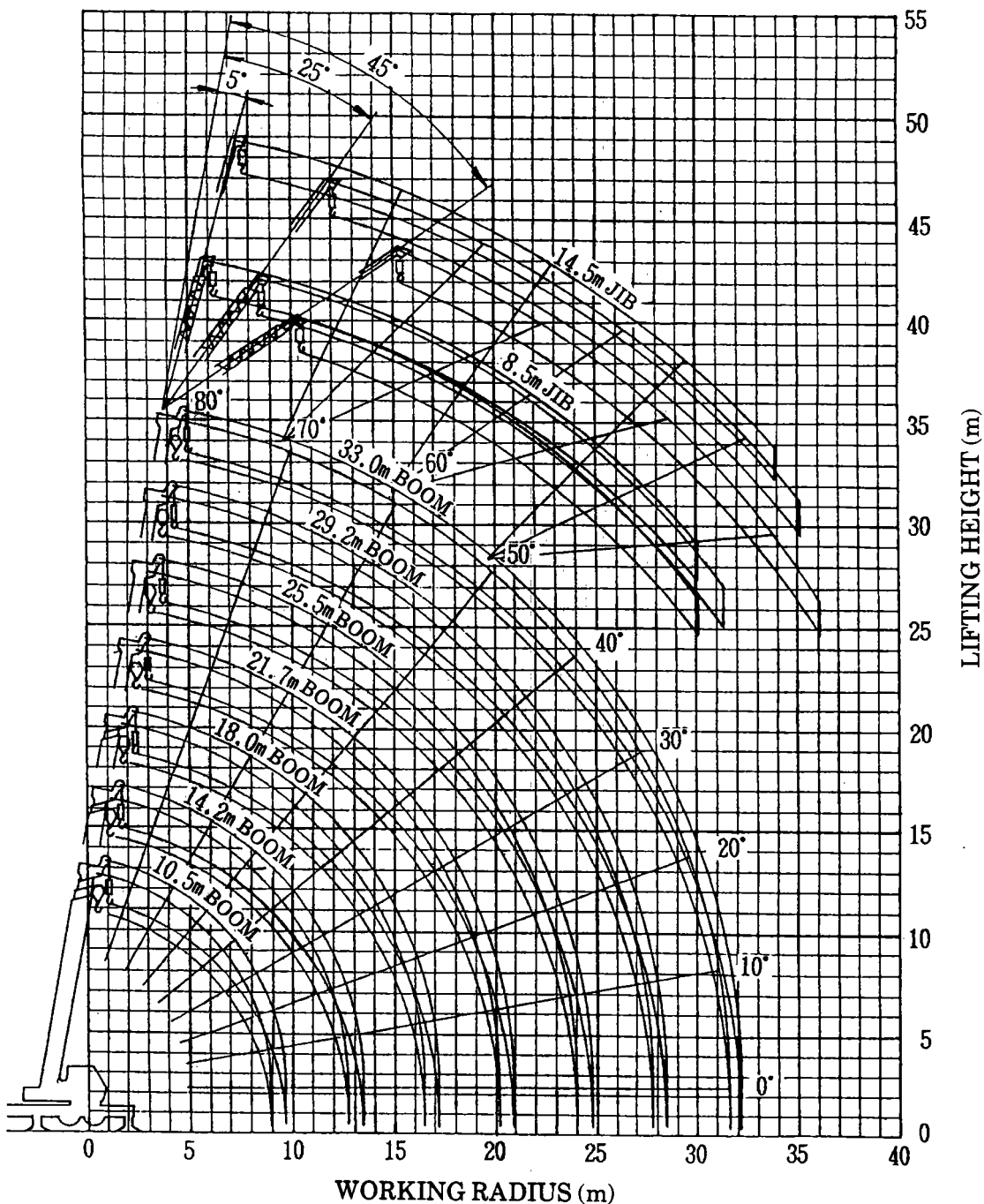

**NOTES:**

1. The deflection of the boom is not incorporated in the figure above.
2. The above chart is for the case where the outriggers are fully extended and where the front jack are used (over 360°).

**DIMENSIONS** (1/100)  
**P-KG45S**

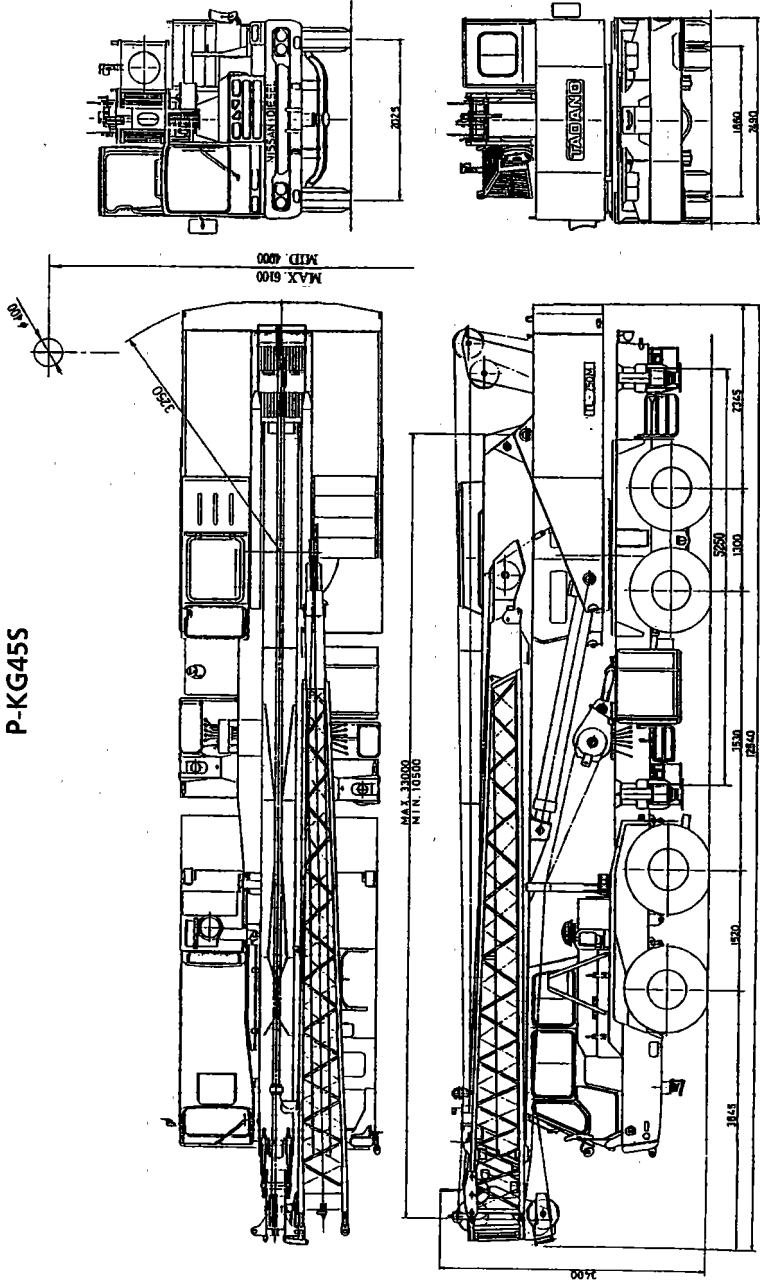

**DIMENSIONS (1/100)**

P-K303

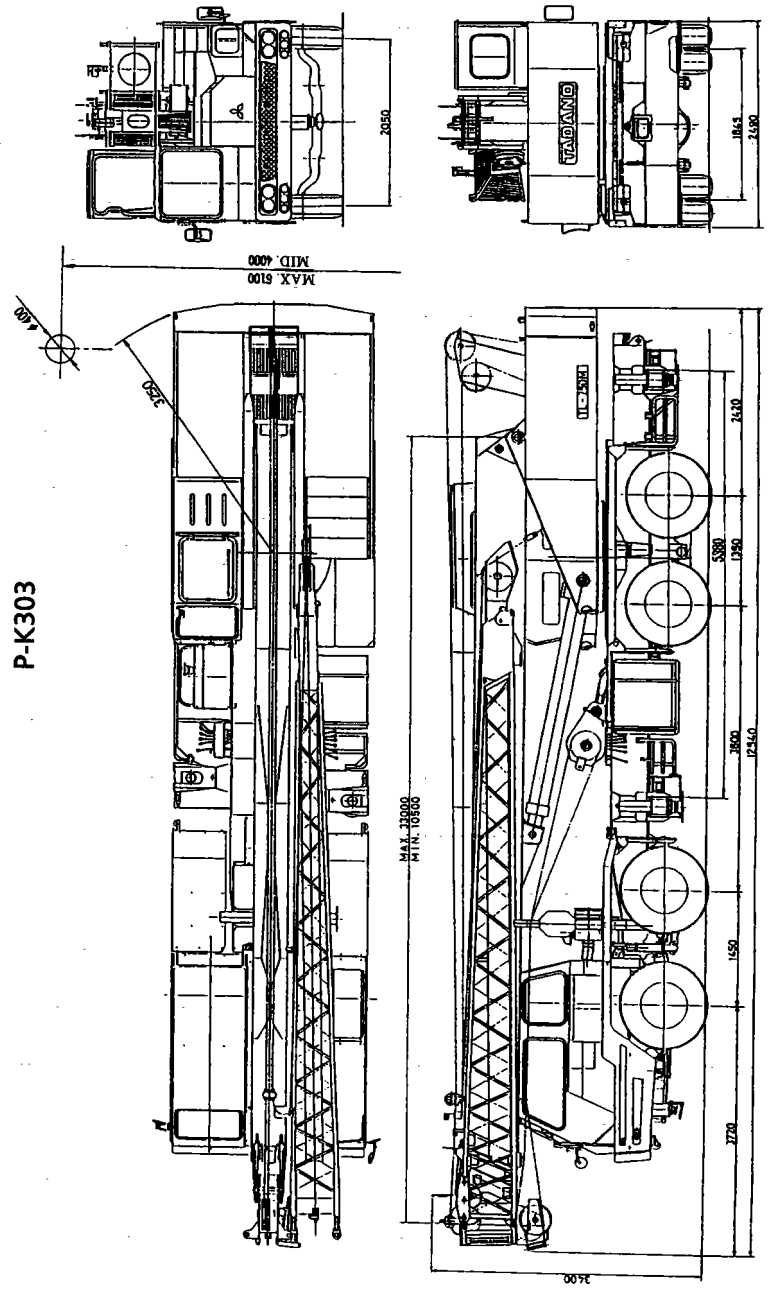

◆ MEMO ◆

A series of horizontal dashed lines for writing.